

NUMERICAL ANALYSIS OF EFFECTIVENESS OF STRENGTHENING CONCRETE SLAB IN TENSION OF THE STEEL-CONCRETE COMPOSITE BEAM USING PRETENSIONED CFRP STRIPS

Iwona JANKOWIAK¹, Arkadiusz MADAJ
Poznan University of Technology, Poznań, Poland

Abstract

One of the methods to increase the load carrying capacity of the reinforced concrete (RC) structure is its strengthening by using carbon fiber (CFRP) strips. There are two methods of strengthening using CFRP strips - passive method and active method. In the passive method a strip is applied to the concrete surface without initial strains, unlike in the active method a strip is initially pretensioned before its application. In the case of a steel-concrete composite beam, strips may be used to strengthen the concrete slab located in the tension zone (in the parts of beams with negative bending moments). The finite element model has been developed and validated by experimental tests to evaluate the strengthening efficiency of the composite girder with pretensioned CFRP strips applied to concrete slab in its tension zone.

Keywords: composite beam, FE analysis, CFRP strips, strengthening of composite beam, concrete in tension, Concrete Damage Plasticity model

1. INTRODUCTION

One of today's well-known methods to increase the load carrying capacity of the RC structure is its strengthening by using CFRP strips. This method involves attaching carbon strips to the surface of structure being strengthened. There are two methods of attaching strips - passive and active one. In the passive method

¹ Corresponding author: Poznan University of Technology, Institute of Civil and Environmental Engineering, Piotrowo st 5, 60-965 Poznań, Poland, e-mail: iwona.jankowiak@put.poznan.pl, tel.+48616475828

a strip is applied to the concrete surface without initial strains [5,6,8], unlike in the active method a strip is initially pretensioned before application to the strengthened element [9]. In the case of steel-concrete composite structures this method may be used to strengthen the concrete slab located in the tension zone (in the parts of beams with negative bending moments). In order to make a decision about the most effective way of strengthening, both ultimate and serviceability limit states have to be taken into account. Today the usage of numerical simulation may help a lot to determine the proper method of strengthening structure before its application. It requires however defining a proper modelling procedure and developing a verified numerical model. The finite element (FE) model which has been developed and validated earlier [7,10,11,12] was used in the present study to evaluate the strengthening efficiency of the steel-concrete composite girder with pretensioned CFRP strips applied to concrete slab in its tension zone.

2. VALIDATION OF FE MODEL

The parametric analysis of different cases of strengthening of concrete slab in tension of composite beam using CFRP strips was performed based on validated numerical models of steel-concrete composite beams tested experimentally at the Institute of Civil and Environmental Engineering in Poznan University of Technology [15].

All tested beams had the same layout of cross section (Fig. 1). The steel beams type PN300 were made of steel with the yield strength about 273,0MPa and the ultimate tensile strength 430,0MPa (maximum elongation 36,1%). Connection between the bottom surface of concrete slab and top flange of steel beam was executed by means of stiff steel shear joints (3,0x5,0x8,0cm) with loop endings distributed at regular spacing at 20cm. This connection method was to ensure the proper rigidity of connection over the entire load range.

In slabs two different steel reinforcement ratios were adopted - 12 ribbed reinforcing bars of diameter 10mm or 14mm were used. The shear reinforcement consisted of 4,5mm round stirrups at intervals of 15cm along the whole beams.

For the 14mm reinforcing bars the measured yield strength was 357,5MPa when the ultimate tensile strength was equal to 457,4MPa. The steel of 10mm reinforcing bars, without an explicit yield plateau, had the 0,2% yield proof-stress of 698,3MPa (the ultimate tensile strength 863,7MPa).

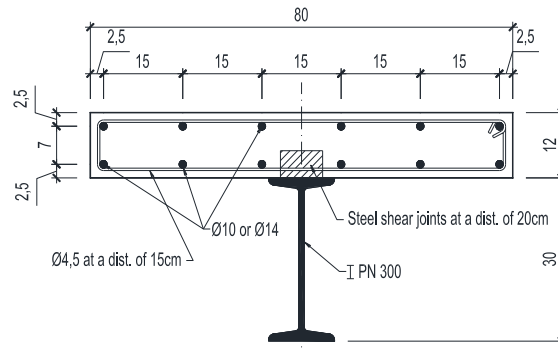

Fig. 1. Cross section of analysed composite steel-concrete beam with arrangement of reinforcing bars in concrete slab

The concrete slabs were made of concrete with modulus of elasticity determined on cube specimens as 30,745GPa and the concrete compressive cube strength measured as 32,37MPa. The tensile strength of concrete determined from the indirect tests was equal to 1,84MPa.

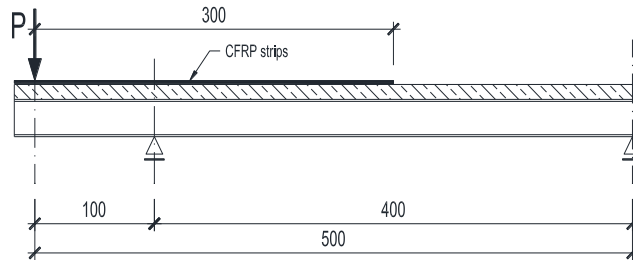

Fig. 2. Numerically studied case of CFRP strip strengthening of concrete slab in tension of analysed composite beam

For strengthening of concrete slabs in tension of composite beams CFRP strips of length of 3,0m, width of 0,05m and a thickness of 1,2mm were used (Fig. 2 and Fig. 3). The modulus of elasticity of CFRP material is equal to 160GPa and the Poisson's ratio is 0,2.

A more detailed description of tested beams and the results of experiments as well as numerical modelling analyses are presented in the papers [7,10,11,12,15]. During experimental research the displacement of composite girder and strains in steel beam and concrete slab were measured in many points. The layout and width of cracks were also recorded. Numerical analyses were focused on searching for the material models, first of all the tensile concrete model and the model of connection of steel beams and concrete slabs, with particular emphasis on the direction of force action in slab (compression, tension) and on the connection models.

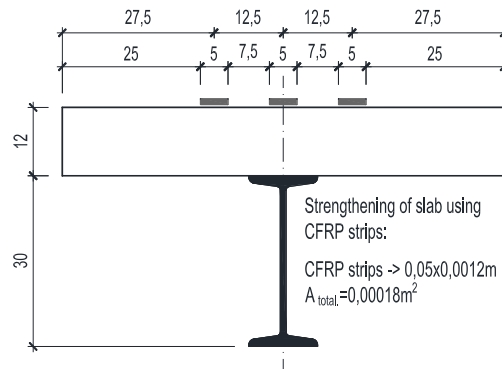

Fig. 3. Analysed case of strengthening of slab of composite beam using CFRP strips

The exemplary validation result of FEA 3D models based on the results of laboratory tests for analysed beam is shown in Fig.4, where the graph of the deflection of the end of cantilever vs. load is presented. Good compatibility of results is obtained. More validation results may be found in [11].

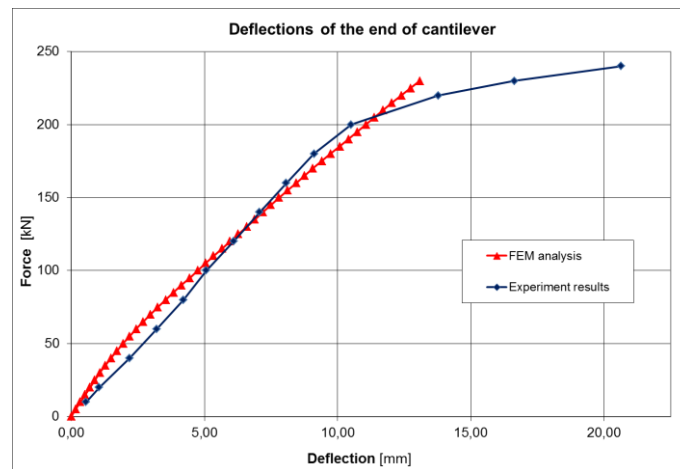

Fig. 4. Comparison of FEA and the experiment results - deflection of end of cantilever of composite beam (shown in Fig.2)

3. FEM ANALYSIS

3.1. FEM model

The numerical analysis was performed using the finite element method. All models of composite concrete-steel beams were created and calculations were carried out using the Abaqus/Standard code [1,2].

The concrete was modelled as the concrete damage plasticity (CDP) material model [13,14,16] including a proper value of tensile fracture energy used to represent the behaviour of concrete in tension [3]. It was assumed that reinforced concrete can work in tensile zones even after cracks occur ('tension stiffening' effect). The strain-softening behaviour of concrete in tension was given as the stress-displacement relationship (σ - w) [17], according to concept of fictitious cracks model of Hillerborg [4]. The material of CFRP elements was modelled as linear elastic isotropic up to failure. In this study, the unidirectional strips were treated as an isotropic and homogenous material for simplicity because their stiffness in the transverse direction exerts negligible influence on the flexural behaviour for beam. The adhesive between the concrete slab and the CFRP strip was neglected - it was assumed that the strip was bonded perfectly to a concrete surface (lack of slipping and debonding).

The concrete damaged plasticity model assumes that the reduction of the elastic modulus is given in terms of a scalar degradation variable d :

$$E = (1 - d)E_0 \quad (1)$$

where: E_0 is the initial (undamaged) modulus of the material.

Thus, the degradation of the elastic stiffness is characterized by two damage variables, d_t (tension) and d_c (compression), which are assumed to be functions of the plastic strains, temperature and other field variables. The damage variables can take values from zero, representing the undamaged material, to one, which represents total loss of strength. In this analysis the elastic degradation of concrete after cracking defined by means of the tensile damage parameter d_t was also included. In the absence of more precise data a simply linear relationship of d_t - w (damage parameter - width of crack) was accepted.

The steel of reinforcing bars as well as the steel of T-girder were modelled as linear elastic-plastic material with isotropic hardening. The reinforcement rebars (main rebars and stirrups) were modelled in a discrete manner as 2-node truss elements embedded in 4-node 2D elements of the plane stress state. During preparation of the 3D models of beams different types of finite elements were combined together (Fig. 5).

The concrete slab was modelled by means of 8-node 3D solid elements with reduced integration (type C3D8R), steel girder by means of 4-node quadrilateral membrane elements with reduced integration (type M3D4R) and bars of main longitudinal reinforcement in concrete slab using 2-node 3D stress/displacement single truss elements (type T3D2). All stirrups in concrete slab were smeared on a surface of membrane (type SFM3D4R). Composite strips were modelled by means of membrane elements.

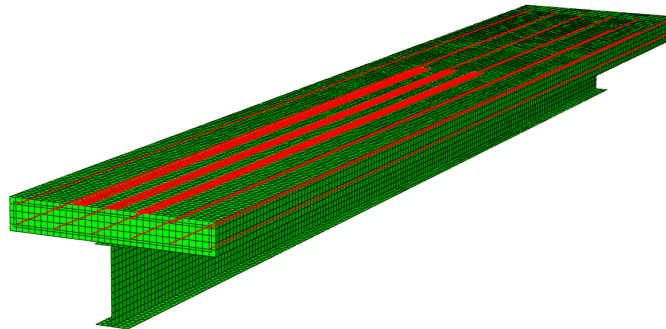

Fig. 5. View on the FE model of composite girder - the steel rebar in concrete slab and the CFRP strips on top surface of concrete slab are shown in red

The connection between bottom surface of concrete slab and upper surface of top flange of steel girder was modelled as discrete “local” connection. This approach was based on imitation the occurrence of stiff shear connectors which exist in the real steel-concrete composite beam. The special elements, so-called connectors type “beam” of infinite stiffness in bending and shear were used. Additionally, the contact surfaces between concrete slab and steel girder were defined with proper friction coefficient equal to 0,5.

The connection between upper surface of concrete slab and CFRP strips was modelled using continuous “tie” connection. During the experiments with reinforced concrete beams strengthened using carbon strips it was shown that delamination between strips and concrete surface occurred always in concrete cover layer and never in the adhesive layer [5]. For this reason the presence of adhesive layer was omitted in the FE model because it has negligible impact on the mode of failure of strengthened beam.

The analysed models were loaded by concentrated force applied to the mesh nodes on the slab. In order to achieve a uniform load over the entire surface of the force distribution, the same vertical displacement constraints were defined for neighbouring nodes of the mesh. As a result, the concentrated forces were distributed in a field equal to 0,15x0,50m.

In the FE analysis the influence of CFRP strip anchorage system (special shape and anchorage heads) was neglected - only the general effect of pretensioning of strip on the RC beam was taken into account.

3.2. Assumptions of parametric study and scope of analysis

Using the created numerical models of composite beams strengthened with CFRP strips the analysis of effectiveness of strengthening concrete slabs in tension zone for passive and active strengthening methods was performed.

The purpose of the analyses was:

- to show the overall (qualitative) assessment of the efficiency of strengthening of concrete slab of composite beam using CFRP strips,
- to determine the effect of differentiated pretensioning of composite strips on the strengthening efficiency.

A reference beam (without strengthening) as well as two other general strengthening cases were analysed numerically. In the last two cases three CFRP strips were adopted as a strengthening elements with a length of 3,0m and a total cross section area of 0,00018m².

Table 1. Cases of active strengthening - the initial strains in CFRP strips in FEA models

No.	Initial strain [‰]	Force strengthening CFRP strips [kN]	% of limit strain
1	4,0	38,1	23,0
2	5,0	47,7	28,0
3	6,0	57,2	34,0
4	7,0	66,8	40,0
5	8,0	76,3	45,0

Therefore, the following cases were analysed:

- a cantilever composite beam without any strengthening (Fig.1),
- a cantilever composite beam with passive strengthening of concrete slab without initial pretensioning [8] (Fig.2, Fig.3),
- a cantilever composite beam with active strengthening of concrete slab with initial pretensioning. A limit level of pretensioning of every composite strips before its application to the top surface of concrete slab was assumed to be of 45% of limit strain of strip at failure which corresponded to the initial strain equal to 8,0‰ and pretensioning force of 76,3kN [9] (Fig. 2, Fig. 3).

In the range of the active strengthening, cases of different pretensioning levels of strips prior to their application to the concrete surface were analyzed. These cases are summarized in Table 1.

4. RESULTS OF PARAMETRIC STUDY

The numerical analyses of cantilever composite beams with proposed ways of CFRP strips strengthening, according to Fig.2, Fig.3 and Table 1, were carried out. It was assumed that the load carrying capacity of all analysed beams is defined as the force at which the stress in the reinforcing bars in the slab above the support reaches the value equal to the yield stress (265 MPa). In all cases, the steel beams of composite beams reached the yield stress in the zone of support at the load equal to 205 kN. This shows that the effect of used strips on the work of beams is visible only in the range of elasto-plastic behaviour of the steel beam.

The limit load carrying capacity of beams were calculated as well as the damage parameter d_t which mimics the layout of cracks distribution on concrete slab. In Fig.6 the deflections of the end of the cantilever of analysed beams are shown. The other selected results are presented in Table 2.

Table 2. Comparison of results of FEM analysis:

No.	Beam	Ultimate load [kN]	The relative increase [%]
1	Without strengthening (reference beam)	295,0	-
2	Passive strengthening	344,5	16,8
3	Active strengthening (for $\varepsilon=0,008$)	368,0	24,7

In the case of composite beams strengthening by the same amount of composite material (with the same cross-sectional area) but pretensioned with different force values, it can be seen that value of initial pretensioning has not significant influence on the element stiffness (Fig.6). However, the level of strip pretensioning may be significant for increasing the limit load carrying capacity of the composite beam by delaying the yielding of the reinforcing steel in the concrete slab. The increase of the limit load carrying capacity can be higher nearly of 25%.

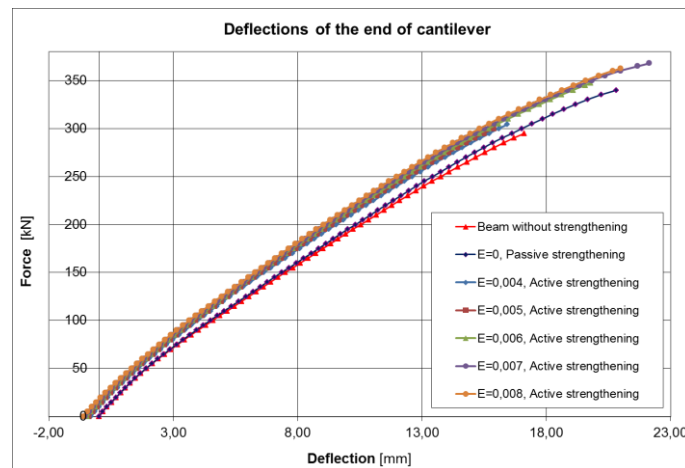

Fig. 6. Comparison of FEA and the experiment results -deflection of end of cantilever for passive strengthening and for active strengthening for different levels of initial pretensioning of CFRP strips

The distribution of the parameter d_t in concrete slabs was analysed. Fig. 7 shows an example of map of the layout of the parameter d_t on the slab of composite beam strengthened with active CFRP strips with the initial strain equal to $\varepsilon=0,008$

(corresponding to the force of 76,3kN). The decomposition of d_t on the concrete slab shows that initial pretensioning of strips can affect not only the initiation and direction of the damages of the slab but also their width.

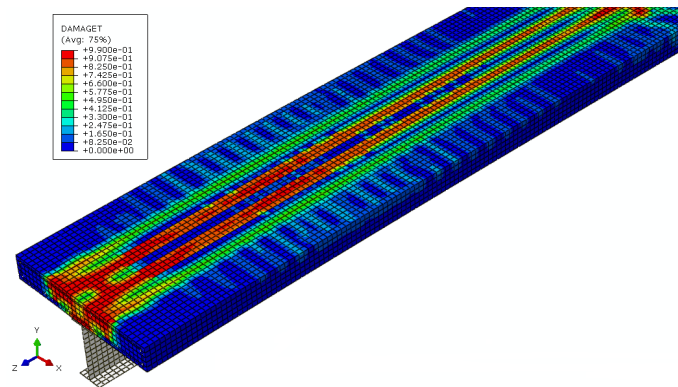

Fig. 7. Distribution of damages defined as d_t parameter on the upper surface of concrete slab in tension strengthened using CFRP strip initially pretensioned with a force equal to 76,3kN (for initial strain $\epsilon=0,008$)

The pretensioning of CFRP strips therefore may lead to increase of its durability, especially when it is exploited under conditions of corrosion risk.

5. CONCLUSIONS

The performed parametric analysis of strengthening concrete slab in tension of the composite steel-concrete beams allows to draw the following final conclusions:

- Adding composite material, both for passive or active methods, does not significantly increase the stiffness of the composite beam. It increases its limit load carrying capacity by delaying the yielding of the reinforcing steel in the concrete slab.
- Applying different values of initial strain in composite strips has a slight impact on increase of the limit load carrying capacity and stiffness of the composite beam.
- Strengthening of composite beams using CFRP strips can significantly improve the durability of the structure by reducing the number and width of cracks.
- More effective strengthening of composite beams using pretensioned CFRP strips may require the use of special anchoring systems for anchoring pretensioned strips in concrete slabs or to the upper steel girder flange. This will be the subject of further analysis of the authors.

REFERENCES

1. ABAQUS User's Manual. Version 6.14. SIMULIA, 2015.
2. ABAQUS/Standard: User's Manual, ABAQUS, SIMULIA, 2014.
3. CEB-FIP Model Code 1990, *Biulletin D'Information*, No. 213/214, CEB Comité Euro-International du Béton, May 1993.
4. Hillerborg, A., Modéer M., Petersson P. E.: *Analysis of Crack Formation and Crack Growth in Concrete by Means of Fracture Mechanics and Finite Elements*, Cement and Concrete Research, Vol. 6, s. 773-782, Pergamon Press Inc., USA, 1976.
5. Jankowiak I.: *Efektywność wzmocniania materiałami kompozytowymi żelbetowych belek mostowych*, Rozprawa doktorska, Politechnika Poznańska 2010.
6. Jankowiak I.: *Analysis of RC beams strengthened by CFRP strips - experimental and FEA study*, Archives of Civil and Mechanical Engineering 12 (2012), pp.376-388, 2012.
7. Jankowiak I., Kąkol W., Madaj A.: *Identyfikacja modelu numerycznego ciągłej belki zespolonej na podstawie badań laboratoryjnych*, VII Konferencja Naukowa „Konstrukcje Zespolone”, Oficyna Wydawnicza Uniwersytetu Zielonogórskiego, Zielona Góra 2005.
8. Jankowiak I., Madaj A.: *Analiza numeryczna wzmocnienia taśmami CFRP betonu w strefie rozciąganej stalowo-betonowej belki zespolonej*, Inżynieria i Budownictwo, ISSN 0021-0315, 4/2015, str. 208-212, 2015.
9. Jankowiak I., Madaj A.: *Load carrying capacity of RC beams strengthened by pre-tensioned CFRP strip*, Recent Advances in Computational Mechanics, CRC Press/Balkema - 2014, London, pp. 95-101.
10. Jankowiak I., Madaj A.: *Numeryczne modelowanie zespolenia płyty betonowej z dźwigarem stalowym*, w monografii „Konstrukcje zespolone”, t. VIII (praca zbiorowa pod redakcją Tadeusza Bilińskiego i zespołu), str. 131-148, Zielona Góra 2008, Oficyna Wydawnicza UZ.
11. Jankowiak I., Madaj A.: *Numeryczny model dźwigara zespolonego stalowo-betonowego z rozciąganą płytą betonową*, w monografii „Konstrukcje zespolone”, t. IX (praca zbiorowa pod redakcją Tadeusza Bilińskiego i zespołu), str. 57-76, Zielona Góra 2011, Zakład Poligraficzny UZ.
12. Jankowiak I., Madaj A.: *Stalowo-betonowy dźwigar zespolony z rozciąganą płytą betonową*, Inżynieria i Budownictwa, 12/2011, str. 667-671.
13. Lee J., Fenves G.L.: *Plastic-damage model for cyclic loading of concrete structures*, Journal of Engineering Mechanics, Vol. 124 (8), 1998, s. 892-900.
14. Lubliner J., Oliver J., Oller S., Onate E.: *A plastic-damage model for concrete*, International Journal of Solids and Structures, vol.25, no.3, s. 299-326, 1989.

15. Madaj A.: *Doraźna nośność i sztywność na zginanie zespolonych belek stalowo-betonowych*, Politechnika Poznańska, Wydawnictwo PP 2005.
16. Oller S., Onate E, Oliver J., Lubliner J.: *Finite element nonlinear analysis of concrete structures using a „Plastic-Damage model”*, Engineering Fracture Mechanics, Vol.35, No. 1/2/3, 1990, s. 219-231.
17. Wittmann F.H., Rokugo K., Bruhwiler E., Mihashi H., Simonin P.: *Fracture energy and strain softening of concrete as determined by means of compact tension specimens*, Materials and Structures, 1988, 21, s. 21-32.

ANALIZA NUMERYCZNA SKUTECZNOŚCI WZMOCNIENIA WSTĘPNIE
NAPRĘŻONYMI TAŚMAMI CFRP ROZCIĄGANEJ PŁYTY STALOWO-
BETONOWEJ BELKI ZESPOLONEJ

Streszczenie

Jednym ze sposobów zwiększenia nośności konstrukcji betonowej jest jej wzmocnienie przez zastosowanie taśm z włókien węglowych (CFRP). Wzmacnianie polega na mocowaniu lub doklejaniu ich do powierzchni konstrukcji. Stosuje się dwa sposoby mocowania taśm: tzw. sposób bierny lub czynny, czyli bez lub z wcześniejszym napięciem taśmy przed jej aplikacją na wzmacnianej konstrukcji. W przypadku stalowo-betonowych konstrukcji zespolonych taśmy mogą mieć zastosowanie do wzmacniania płyty betonowej w strefie działania momentów powodujących jej rozciąganie. Jednym ze sposobów znalezienia najbardziej skutecznego sposobu wzmocnienia przed jej zastosowaniem jest wykorzystanie symulacji numerycznych. Wymaga to opracowania poprawnego modelu obliczeniowego, który musi być zweryfikowany badaniami empirycznymi. Autorzy artykułu opracowali taki model numeryczny i zastosowali go do oceny skuteczności wzmocnienia omawianego typu dźwigara zespolonego taśmami CFRP wstępnie naprężonymi.

Słowa kluczowe: belka zespolona, analiza MES, taśmy CFRP, wzmacnianie belek zespolonych, beton rozciągany, model betonu plastycznego ze zniszczeniem

Editor received the manuscript: 29.09.2017